

Easy Multifunctional Safe

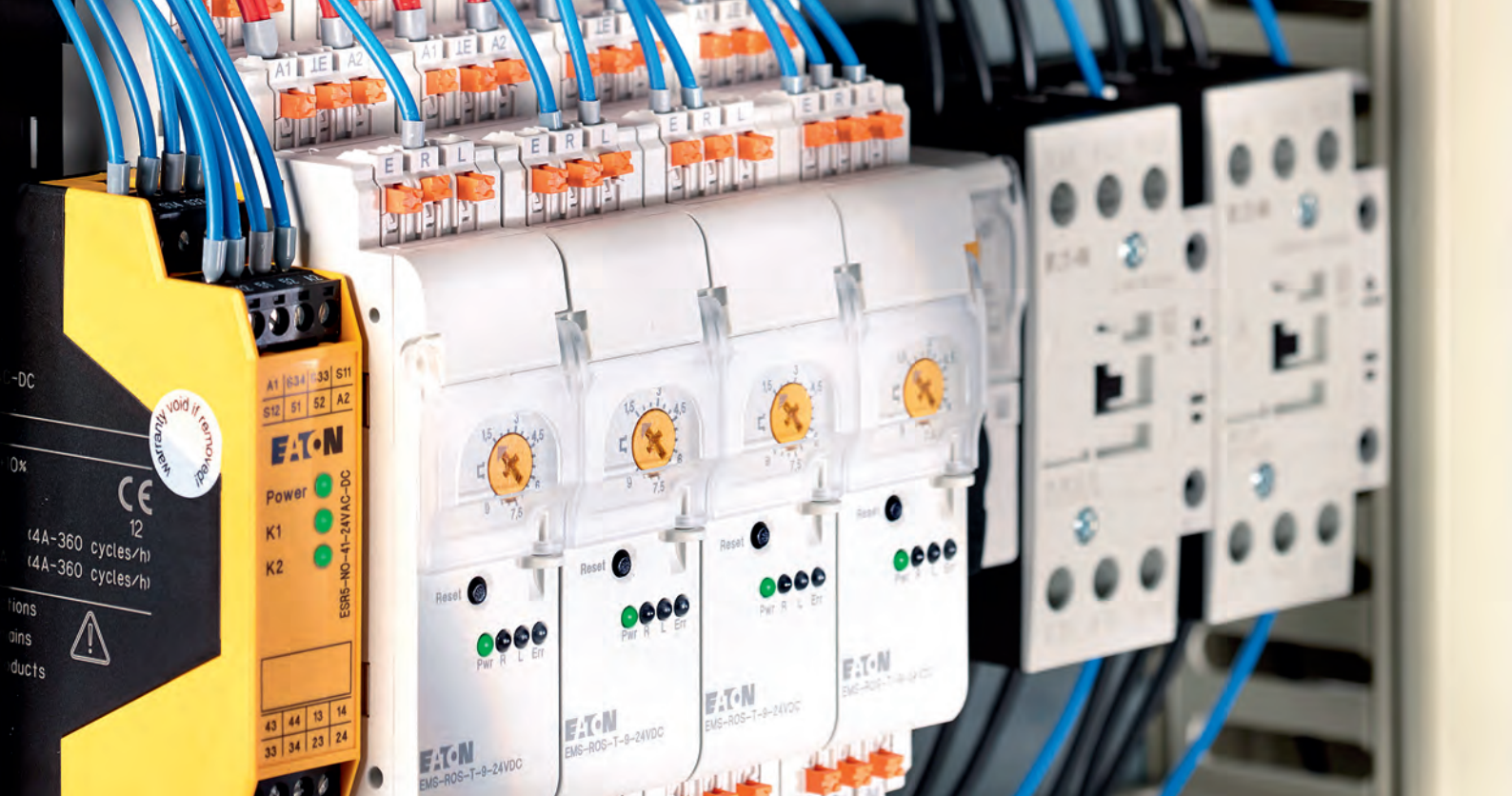

Powering Business Worldwide



EMS – Multifaceted Performance with only 30 mm

Eaton Moeller® series products have always embodied quality and reliability in the machine building industry. As many know, this applies in particular to our PKZ motor-protective circuit-breakers and DIL contactors, which continue to set new standards to this day. Our new EMS electronic motor starters not only continue with this tradition, but are also a leap into fully electronic motor starters, and therefore a leap into the future.

Defining the future.

Trendsetting is simply another word for action. This is why it was only natural for renowned Eaton products such as our DIL contactors and PKZ motor-protective circuit-breakers to be further developed and expanded on.

The result is the new series of PKE motor protection systems with electronic wide-range overload protection for state-of-the-art systems intended to increase machine availability above all.

Motor start from the tiniest space.

With its EMS electronic motor starter, Eaton is setting a new standard by offering a multifunctional motor protection and control relay with a frame width of 30 mm. This electronic motor starter is intended for applications in which motors with a performance range from 0.06 kW to 3 kW need to be reliably driven and protected while using up as little space as possible. Accordingly, four functions have been incorporated into this single switching device:

- DOL starter
- Reversing starter
- Motor protection as per IEC 60947

- Safety-oriented drive stopping in accordance with category 3 (EN 13849)

This electronic motor starter is mainly intended for applications in which motors have to be controlled and protected in the following systems:

- Logistics systems
- Material handling systems, small elevators
- Packaging machines
- Production machines
- Machine tools



Features at a glance

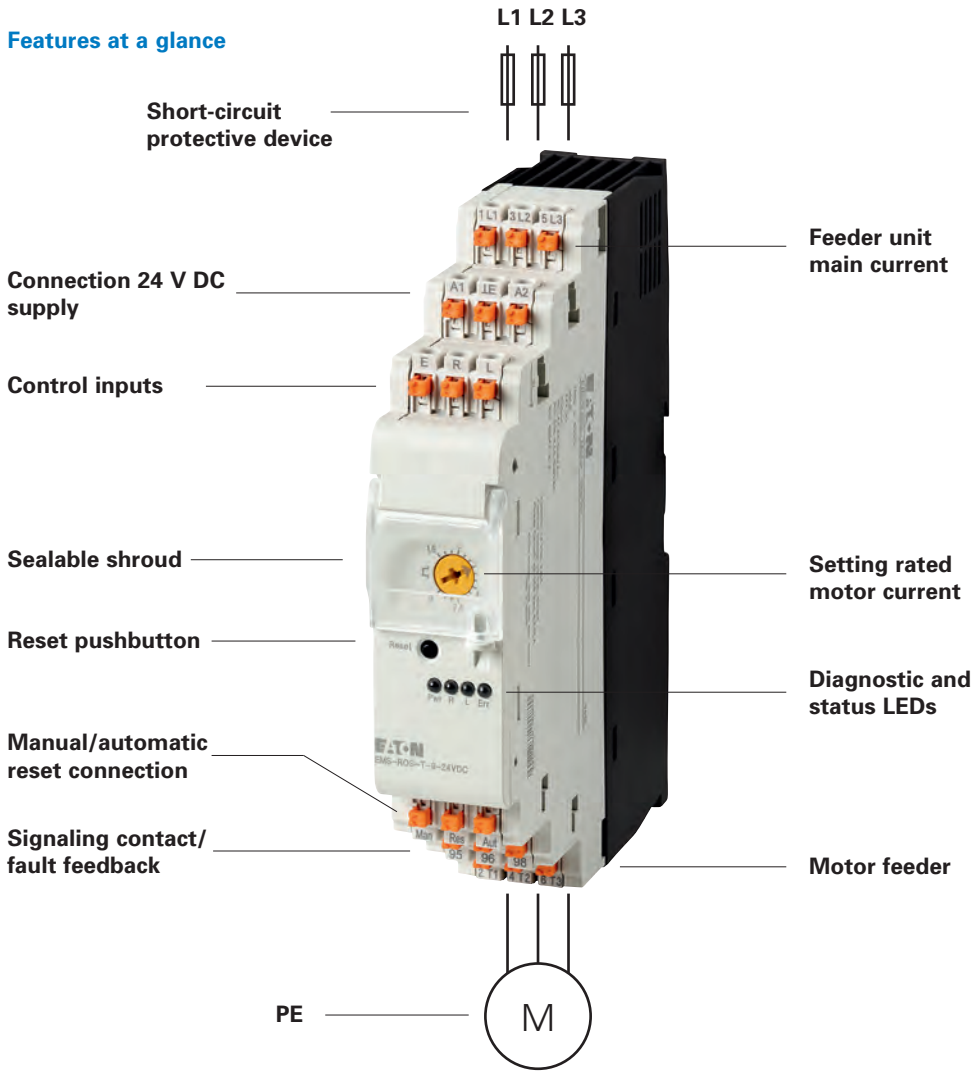

Always the right tripping class.

The electronic motor starter's motor protection is implemented using two different tripping classes. For motor currents greater than 4 A, a Class 10 A time-current curve is used for motor protection. Meanwhile, for motor currents of up to 4A,

a slower Class 10 time-current curve is used for motor protection. This curve prevents the motor protection mechanism from tripping prematurely in the event of frequent start/stop operations or high inrush currents.

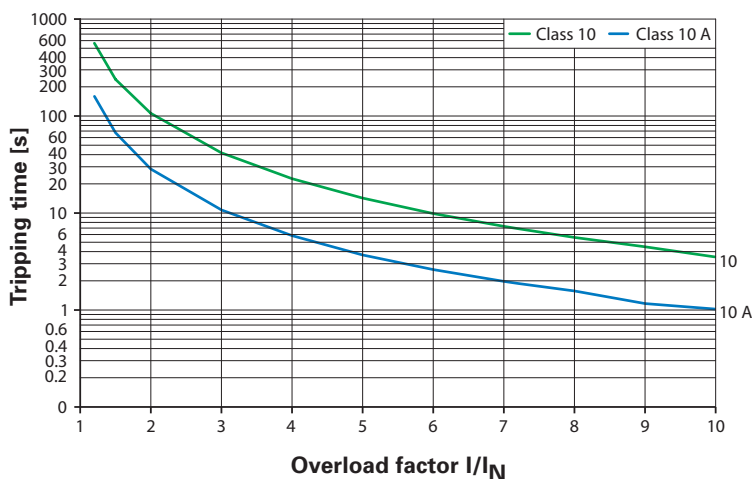
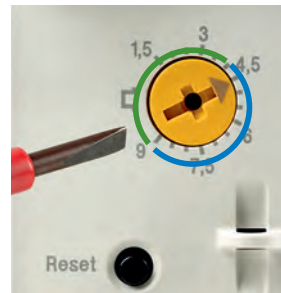

Four functions in a single device



DOL start with high contact life

Integrated hybrid switching provides the electronic motor starter with a significantly longer contact life than conventional switching devices. How long is longer? A total of 30 million switching operations.



Motor starter with DOL and reversing capabilities

The electronic motor starters feature an integrated reversing circuit in order to drive motors in the forward and reverse directions. This eliminates the need for additional switching devices.



Emergency-stop actuator

The electronic motor starter can be used to set up safety circuits with a performance level of e or a safety integrity level of 3 without the need for additional switching devices in the main current path.



Integrated motor protection as per IEC 60947

All EMS electronic motor starters come with electronic wide-range overload protection with additional detection of phase unbalances as per IEC 60947. This eliminates the need for additional motor protection elements.



EMS – Complex Functions Made Simple

Reversing starter with emergency stop

Main circuit

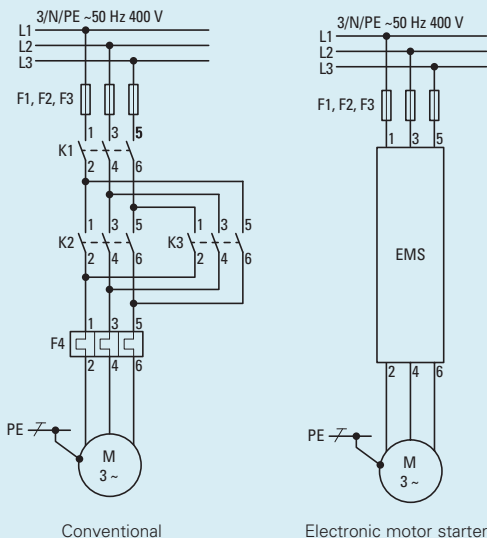

Actuating circuit

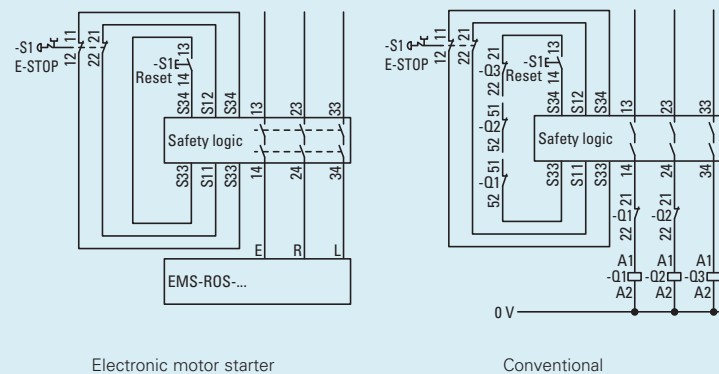

Faster for increased safety

EMS motor starters make it possible to implement applications with safety-oriented stopping in accordance with cat. 3 /SIL 3 and PLe much faster and easier than conventional motor starters.

In addition, wiring is less complex both at the main circuit and actuating circuit levels. In total, installation efforts are reduced by up to 60%, while the number of required hardware components is reduced by 70%.

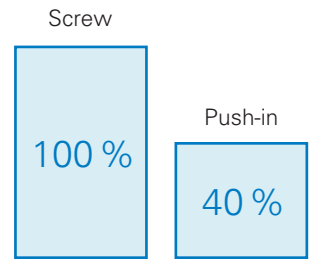
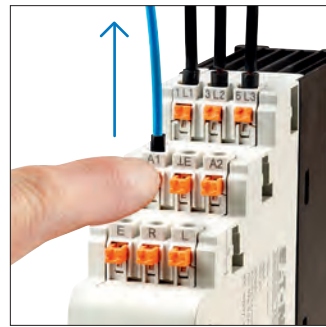
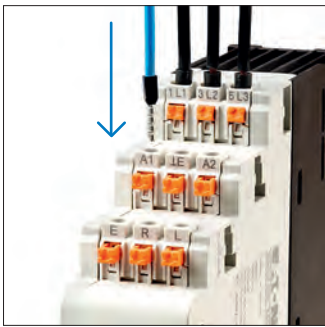

Time comparison

Smart terminal type

The electronic motor starter relies on push-in terminals for its main circuit and actuating circuit connections. This enables users to connect and disconnect

the connection cables without tools and reduces the time spent wiring the starter up to 60% in comparison to conventional screw terminals.

This ensures that you will not only benefit from increased safety, but also from faster, simpler, and clearer handling.

Time is money

Reduce the time it takes to install your motor starters by up to 60%. Tool-less push-in terminals ensure that installation is done in the blink of an eye, enabling you to use your time on more important things.

DOL starter

Reversing starter

DOL starter emergency stop

Reversing starter emergency stop

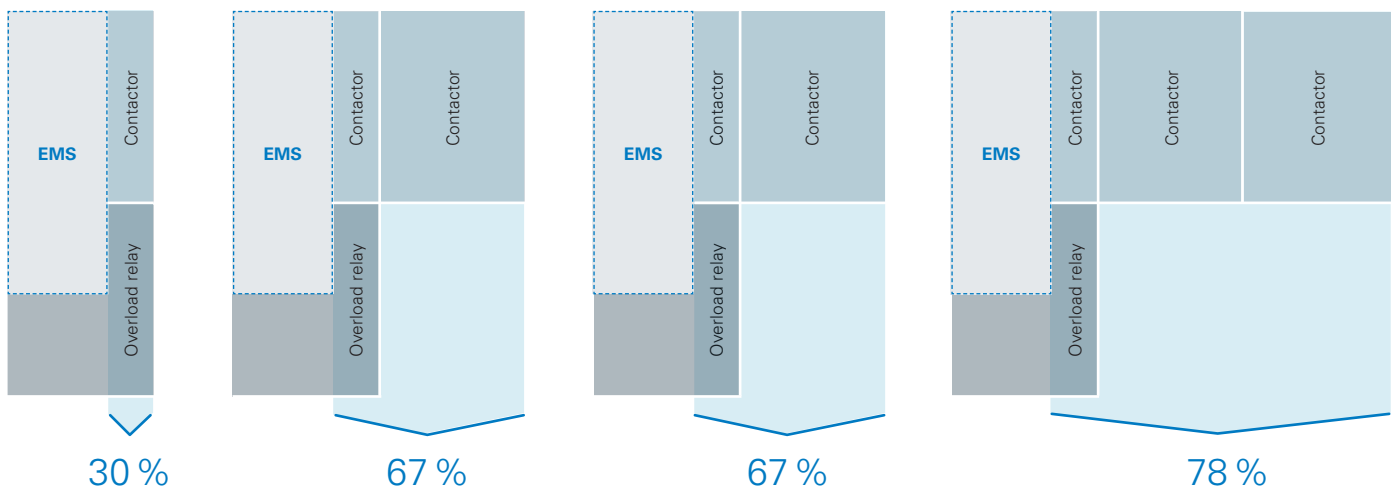

A frame width reduction of up to 78% in comparison to conventional motor starters.

Compact, reliable, safe

A small electronic motor starter frame width of only 30 mm translates into important space savings inside control cabinets. This advantage is particularly important in the case of machines with numerous reversing starters and strict safety requirements (emergency stop), since using these motor starters also makes it possible to eliminate the need for multiple conventional switching devices.

In addition to the space that is freed up, the device's staggered terminals reduce wiring efforts even further. This makes it possible to put together motor starter groups much faster, and the reduction in wiring efforts makes it possible to reduce installation times by 60%.

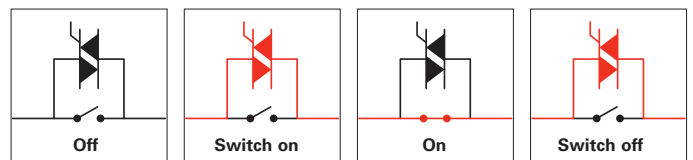

Hybrid switching ensures a longer life

The electronic motor starter's integrated hybrid switching increases its life significantly in comparison to conventional switching devices. The semi-conductor connected in parallel to the main contacts handles the current flow during switch-on and switch-off operations, ensuring that the starter will have a longer contact life of 30 million switching operations.

Electronic motor starter EMS



Function	Setting range Overload protector I _r A	Motor rating AC-53a 380V 400V 415V kW	Part no.	Article no.
DOL starting				
DOL start, motor protection	0.18...2.4	0.06...0.75	EMS-DO-T-2.4-24VDC	170099
DOL start, motor protection	1.5...9 (6.5 AC53a)	0.55...3	EMS-DO-T-9-24VDC	170100
DOL start, motor protection, emergency stop	0.18...2.4	0.06...0.75	EMS-DOS-T-2.4-24VDC	170103
DOL start, motor protection, emergency stop	1.5...9 (6.5 AC53a)	0.55...3	EMS-DOS-T-9-24VDC	170104
Reversing start				
DOL start, reversing start, motor protection	0.18...2.4	0.06...0.75	EMS-RO-T-2.4-24VDC	170101
DOL start, reversing start, motor protection	1.5...9 (6.5 AC53a)	0.55...3	EMS-RO-T-9-24VDC	170102
DOL start, reversing start, motor protection, emergency stop	0.18...2.4	0.06...0.75	EMS-ROS-T-2.4-24VDC	170105
DOL start, reversing start, motor protection, emergency stop	1.5...9 (6.5 AC53a)	0.55...3	EMS-ROS-T-9-24VDC	169789

Prices see price list

Dimensions EMS

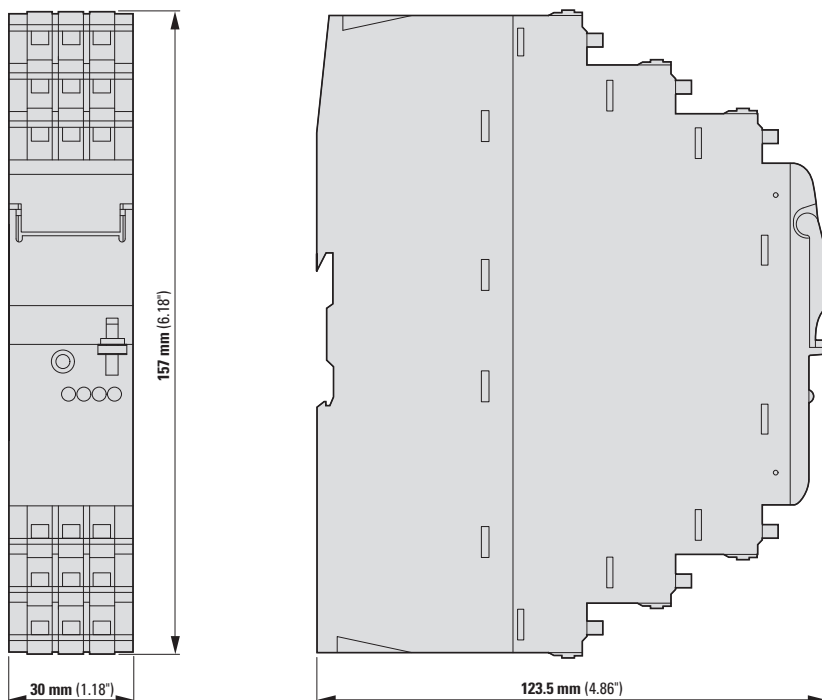

Technical data

General	Standards		IEC/EN 60947-4-2; UL508
	Dimensions (W x H x D)	mm	30x157x123.5
	Weight	kg	0.3
	Mounting		Top-hat rail IEC/EN 60715, 35mm
	Mounting position		Vertical, motor feeder on bottom
	Degree of protection (IEC/EN 60529, EN 50178, VBG 4)		IP20_x
	Lifespan	Operations	3 x 10 ⁷
	Max. switching frequency (50:50 duty cycle)	Operations/h	7200
Terminal capacity	solid	mm ²	1 x (0.75...2.5), 1x(AWG20...14)
	Flexible with ferrule	mm ²	2 x (0.75...2.5), 1x(AWG20...14)
	flexible with twin ferrule	mm ²	2 x (0.75...1.5), 2x(AWG20...16)
			Minimum length 10mm
Electromagnetic compatibility (EMC)	Electrostatic discharge (IEC/EN 61000-4-2, Level 3, ESD)		
	Air discharge	kV	8
	Contact discharge	kV	6
	Electromagnetic fields(IEC/EN61000-4-3)		
	80-1000MHz	V/m	10
	1.4-2 GHz	V/m	10
	2-2.7 GHz	V/m	3
	Emitted interference cable related (EN 55011)		Class A *)
	Radiated emitted interference (EN 61000-6-3)		Class A *)
	Burst pulses (IEC/EN 61000-4-4, level 3)	kV	2
	Surge (IEC/EN 61000-4-5)		
	Symmetric	kV	1
	asymmetrical	kV	2
Radiated RFI (IEC/EN 61000-4-6)	V	10	
Ambient climatic conditions	Operating ambient temperature (IEC 60068-2)	°C	-25...+60
	Condensation		prevent with suitable measures
	Storage	°C	-40...+80
Input data (EMS-...-T-24VDC)	Supply voltage (A1-A2)	VDC	24-20% + 25%
	Supply voltage "confirm Off"	VDC	<5
	Residual ripple	%	5
	Input current (without return signal)	mA	40
Actuating circuit (ON, L, R)	Switching level "Low"	VDC	-3...9.6
	Switching level "confirm Off"	VDC	<5
	Switching level "High"	VDC	19.2...30
	Input current	mA	5
Feedback outputs (95, 96/97, 98)	Contact type		Single contact, 1 changeover contact
	Maximum switching voltage	VAC/VDC	250
	Switching capacity AC-15 (230 VAC)	A	3
	Switching capacity DC13 (24 VDC)	A	2

*) This product is designed for use in industrial environments (environment 2). Its use in residential environments (environment 1) may cause radio-frequency interference, requiring additional noise suppression measures.

Technical data

Power section	Switching principle		Safety output stage with bypass, three-phase disconnect
	Rated operational voltage	VAC	500 (42...550)
	Rated operational current		
	EMS-...-2,4-...		
	AC51 (EN60947-4-3)	A	0.15...2.4
	AC53a (EN60947-4-2)	A	0.15...2.4
	EMS-...-9-...		
	AC51 (EN60947-4-3)	A	1.2...9
	AC53a (EN60947-4-2)	A	1.2...6.5
	Minimum heat dissipation		
	EMS-...-2,4-...	W	1.1
	EMS-...-9-...	W	1.1
	Max. heat dissipation		
	EMS-...-2,4-...	W	3.3
EMS-...-9-...	W	14.6	
Main circuits	Rated impulse withstand voltage	VAC	6000
	Overvoltage category		III
	Pollution degree		2
	Basic insulation (IEC/EN 60947-1)		
	Between supply, control, and switching voltages	VAC	500
	Feedback output and switching voltage	VAC	500
	Safe isolation (IEC/EN 60947-1)		
	Between supply, control, and switching voltages	VAC	≤300 (e.g. 230/400, 277/480)
	Feedback output and switching voltage	VAC	≤300 (e.g. 230/400, 277/480)
	Safe isolation according to EN 50178		
	Between supply, control, and switching voltages	VAC	500
Feedback output and switching voltage	VAC	500	
Ammeter (L1,L3)	Setting range of overload releases		
	EMS-...-2,4-...	A	0.18...2.4
	EMS-...-9-...	A	1.5...9.0
	Motor protection, characteristic		
	$I_r \leq 4A$		CLASS10
	$I_r > 4A$		CLASS10A
	Recovery time	Minimo	20
	Balance monitoring		
	Magnitude of $I_{max} > I_r$ ($I_{max} - I_{min}/I_{max}$)	%	≥33/≥67
	Magnitude of $I_{max} < I_r$ ($I_{max} - I_{min}/I_{rated}$)	%	≥33/≥67
Pick-up time	s	120/1.8	
Stall protection (EMS-...-9-...)	I (L1) or I (L3)	A	>45A
	Pick-up time	s	2
Short-circuit strength type of coordination 1	50kA/500VAC		Fuse 16A gG/gL

Safety engineering		Safe switch off (EMS-DOS-..., EMS-ROS-...)		Motor protection EMS-DO..., EMS-RO...	
MTTFd	Years	127	MTTFd	Years	101
λ_{sd} [FIT]		193	λ_{sd} [FIT]		0
λ_{su} [FIT]		5205	λ_{su} [FIT]		4794
λ_{dd} [FIT]		893	λ_{dd} [FIT]		1002
λ_{du} [FIT]		8.07	λ_{du} [FIT]		130
SFF	%	99.9	SFF	%	98
DCS	%	3.5	DCS	%	0
DC	%	99	DC	%	88
PFH		8.07 x 10 ⁻⁹			
Sicherheitslevel					
IEC 61508-1		SIL 3	IEC 61508-1		SIL2
ISO 13849-1		PL e			
EN 954-1		Cat. 3			

Derating rated operational current EMS-...-9-...

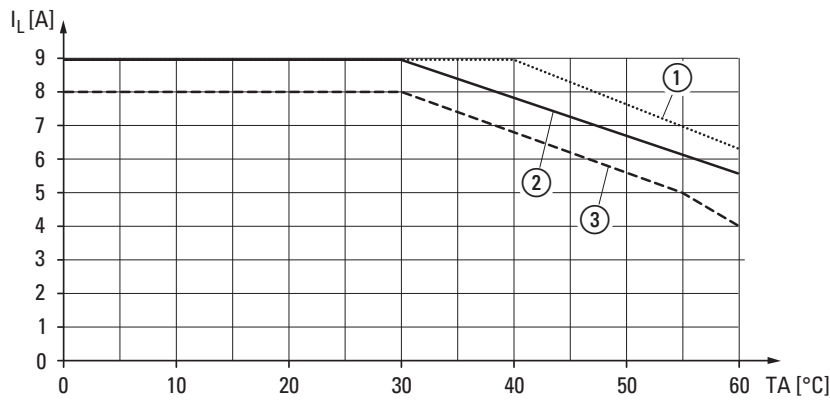

- 1 Stand-alone device
- 2 Connected in series, with a distance equal to one housing width (30 mm)
- 3 Connected in series, without any distance

Engineering rated operational current

Derating curve EMS-...-9-...										
Utility category	AC-51							AC-53a		
Overcurrent factor I_M/I_N	1	2	3	4	5	6	7	8	9	10
Adjustment factor K	1	1	1	1	1	0.96	0.83	0.72	0.64	0.58

Example 1			
Motor with overcurrent factor (from motor data sheet)	I_M/I_N	8	
Adjustment factor	K	0.72	
Max. permissible load current at 30° C, not connected in series	I_L	9A	
Max. permissible rated operational current	I_N	6.5A	

Example 2			
Motor with overcurrent factor (from motor data sheet)	I_M/I_N	8	
Adjustment factor	K	0.72	
Max. permissible load current at 60° C, connected in series	I_L	4A	
Max. permissible rated operational current	I_N	2.88A	

Trip type EMS

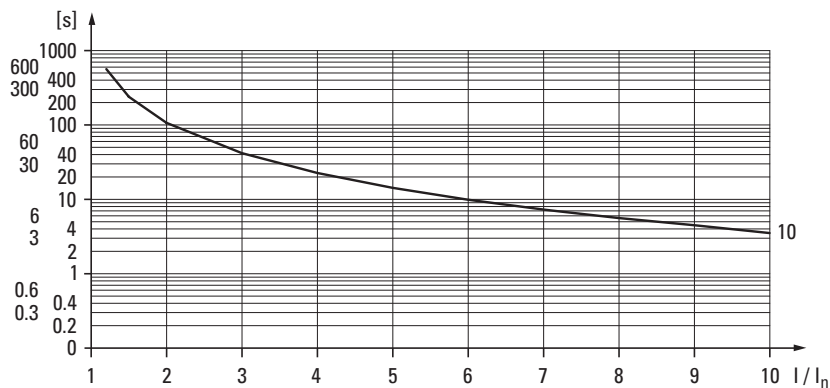

EMS-...-2,4-...
EMS-...-9-... ($I_r \leq 4A$)

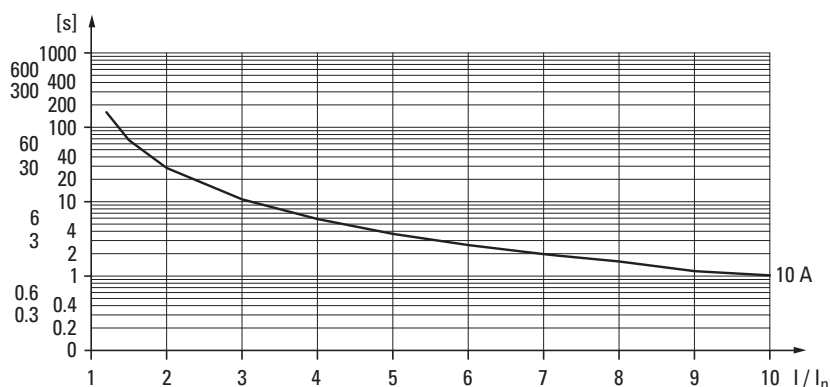

EMS-...-9-... ($I_r > 4A$)

Eaton is dedicated to ensuring that reliable, efficient and safe power is available when it's needed most. With unparalleled knowledge of electrical power management across industries, experts at Eaton deliver customized, integrated solutions to solve our customers' most critical challenges.

Our focus is on delivering the right solution for the application. But, decision makers demand more than just innovative products. They turn to Eaton for an unwavering commitment to personal support that makes customer success a top priority. For more information, **visit www.eaton.com/electrical**.

To contact an Eaton salesperson or local distributor/agent, please visit www.eaton.eu/electrical/customersupport

Changes to the products, to the information contained in this document, and to prices are reserved; so are errors and omissions. Only order confirmations and technical documentation by Eaton is binding. Photos and pictures also do not warrant a specific layout or functionality. Their use in whatever form is subject to prior approval by Eaton. The same applies to Trademarks (especially Eaton, Moeller, Cutler-Hammer). The Terms and Conditions of Eaton apply, as referenced on Eaton internet pages and Eaton order confirmations.

Eaton Industries GmbH
Hein-Moeller-Str. 7-11
D-53115 Bonn/Germany

© 2013 by Eaton Corporation
All rights reserved
Printed in Germany 03/13
Publication No.: BR034001en
ip March 2013
Article No.: 171852



Eaton is a registered trademark of Eaton Corporation

All other trademarks are property of their respective owners.

SmartWire-DT® is a registered trademark of Eaton Corporation.